

6800 Series

Universal Testing Systems



6800 SERIES
the NEXT
GENERATION of
Universal Testing Systems





For over **70 YEARS** the Intron® brand has been widely recognized for producing some of the most advanced mechanical testing systems in the world. Our systems are designed by industry experts, vetted by active members of major standards organizations, and supported by a global network of skilled and experienced service technicians. This comprehensive approach allows us to back each Intron system with an unmatched level of industry and application expertise designed to support it throughout its lifetime.



1500+ employees
A highly-educated, experienced, and diverse workforce



Representing **160 countries**, speaking **40+ languages**

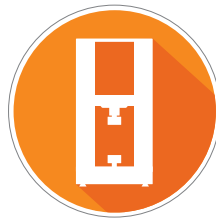

50,000+ systems installed worldwide



70+ years of engineering and manufacturing testing systems

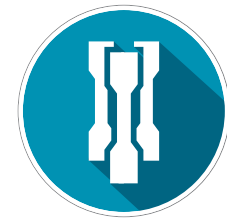

Diverse product range for nearly all global markets and industries

SOLUTIONS FOR ALL OF YOUR TESTING NEEDS

Application-Based Testing Solutions

The 6800 Series Universal Testing Systems range in capacity from 500 N to 50 kN and provide exceptional performance with unparalleled accuracy and reliability. Offering up to 5 kHz data acquisition and $\pm 0.5\%$ accuracy down to 1/1000th of load cell capacity, the 6800 Series offers ultimate flexibility for any testing need.

Single Column Testing Systems

For low force applications, the 6800 single column series provides up to 5 kN capacity available in standard and extra height options.



SCAN THE QR CODE
to learn more and see
the 6800 systems in action.



Table Model Testing Systems

For higher force applications, the 6800 dual column table model series provides up to 50 kN capacity available in standard and extra height/width options.

FLEXIBILITY BY DESIGN

Application-Based Testing Solutions

Instron® systems are routinely found in industries that require the testing of plastics, metals, elastomers and packaging. Some of our key applications can be found in the biomedical, automotive, electronics, and raw materials industries.

The 6800 Series universal testing machines are designed to perform tensile, compression, flex, peel, puncture, friction, shear tests, and more. The systems are compatible with hundreds of grips and fixtures found in Instron's expansive accessories catalog, with specific configurations designed to perform many of the most popular ASTM and ISO tests.

SCAN THE QR CODE
to see Instron's full
Accessories Catalog.



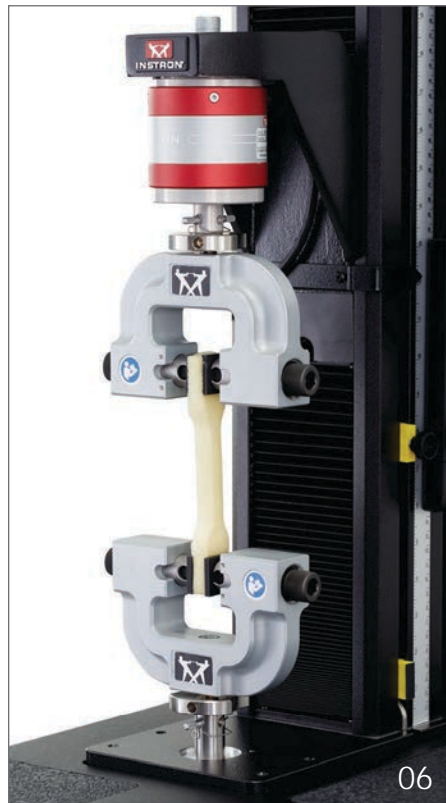
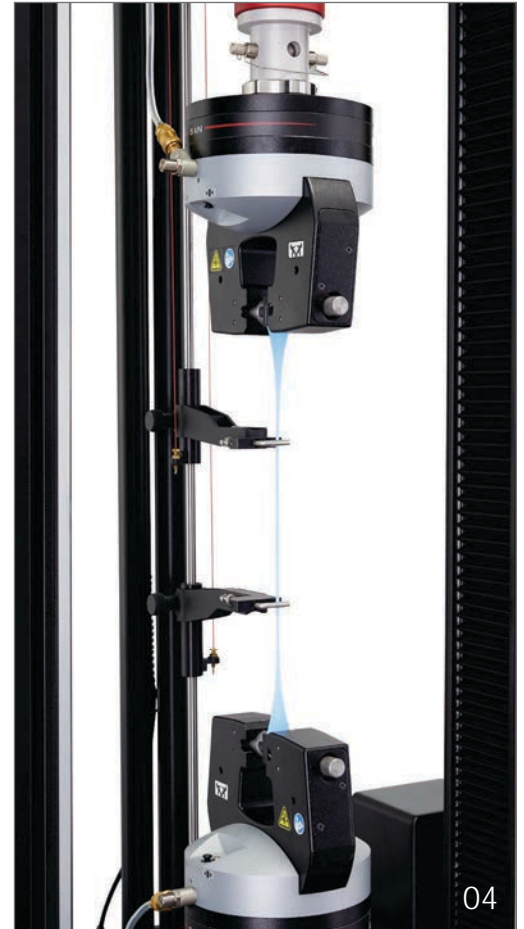

Tensile Testing

- 01 Temperature Chamber with AVE 2
- 02 Cord And Yarn Grips
- 03 Manual Wedge Action Grips & T-Slot Table
- 04 Dual Column XL Extensometer
- 05 Bio Bath & 250 N Pneumatic Grips
- 06 Screw Side Action Grips
- 07 1 kN Pneumatic Grips

FLEXIBILITY BY DESIGN

Application-Based Testing Solutions



Compression and Flexure Testing

- 01 Syringe Compression Fixture
- 02 Three-point Bend Fixture
- 03 10 kN Compression Platens
- 04 100 kN Compression Platens
- 05 Perforated Compression Fixture with Swivel Platen



06



08



10



07



09

Peel, Friction, and Torsion Testing Solutions

- 06 Syringe Test on Torsion Add-On 2.0
- 07 Quick Change Load Cell
- 08 Variable Angle Peel Fixture
- 09 Fully Enclosed Safety Shield
- 10 Coefficient of Friction



Simpler

Powered by Bluehill® Universal

The 6800 Series Universal Testing Systems are powered by Instron's Bluehill Universal Software. Equipped with easy-to-understand icons and workflows, Bluehill Universal makes it simple to train users and set up tests, helping you maximize lab efficiency while minimizing costly errors.



QuickTest

For when you need results fast, QuickTest allows users to enter a few simple parameters and run their test within seconds.



Pre-Loaded Templates

Bluehill Universal includes an extensive library of pre-configured methods for some of the most commonly used ASTM, ISO, and EN standards. The methods are packaged in modules that are specific to your testing application.



Workflow

Users can be guided through the entire testing process with step-by-step instructions, ensuring that their tests remain repeatable, simple, and error-free. The prompts can be easily customized with your own text and images.



Auto Positioning

Auto Positioning saves the correct fixture separation starting location for each test method. This ensures all operators run each test exactly the same way across all shifts every day.



TestProfiler

Build simple cyclic tests that include ramps, holds, and triangle waves. Conditional logic allows users to create looping patterns that help mimic real life scenarios within tests.

SMARTER

Advanced Performance and Applications

The 6800 Series can be expanded to include Digital Input/Output Channels and up to 11 Sensor Conditioning Modules to ensure compatibility with advanced accessories and external devices.

When testing on a 6800 Series frame you can capture synchronized data at a rate of up to 5 kHz with adjustable bandwidth to never miss a test event.

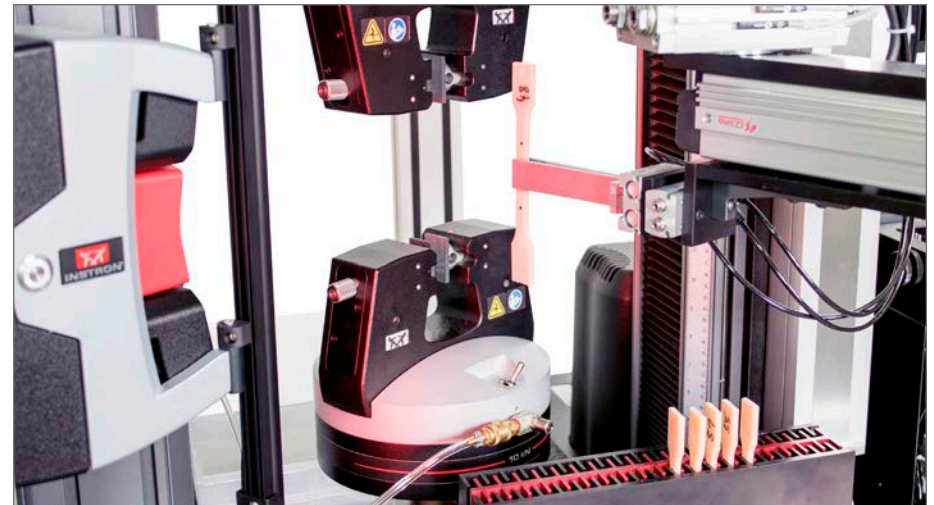

Automated Testing Solutions

Automated Testing Systems built on the 6800 Series Systems enable a new dimension of testing productivity, improve safety, reduce variability, save time and increase throughput. From XY stages to 6-axis robots, automated testing systems can be configured for any application.



Torsion Add-On 2.0

The Torsion Add-On easily mounts to any new or existing 68SC or 68TM system to enable biaxial testing of components such as bone screws, Luer locks, electrical knobs, and more.



AutoX750

High accuracy automatic contacting extensometer produces reliable and repeatable results with no manual steps.



AVE 2

The AVE 2 is a non-contacting video extensometer that provides accurate and repeatable strain measurement without affecting material properties.

SAFER

Safety without Sacrificing Throughput



Operator Protect

The 6800 Series is built on Instron's patent-pending Operator Protect architecture. An intelligent workflow keeps equipment and operators safer by controlling system status from setup to test completion.



Built-in Safety Coaching

The 6800 series provides clear visual feedback regarding system status at all times. Users will easily understand when the system is in a safe setup mode, and clearly reminded to exit the test space once these safety limits are removed.



Smart-Close Air Kit

Finger pinch hazards from pneumatic grips are reduced through lower grip-closing pressure and restricted speed during the setup phase of your test.



The 6800 handset brings system controls closer than ever before with an all-new ergonomic handset, mounted directly to the frame. Operators can use the handset in the mounted position or removed from its dock.

Customizable Soft Keys

With 2 user-defined 'Soft Key' buttons, the operator can initiate a variety of commands. The Soft Keys can be defined per method, allowing for customization for each test.

Virtual Interlock

With Instron's patent-pending system architecture, the machine's movement is restricted during setup to prevent unintended motion of the crosshead.

Variable Speed Jog

During setup mode, your system will default to a safe speed appropriate for an operator to work in the test space.

Precise Positioning

The Fine Position adjustment thumbwheel with tactile feedback allows for precision positioning of the crosshead in 4 μm increments when performing sensitive testing.

Specimen Protect

Specimen Protect prevents unwanted forces from being applied to the specimen by automatically making fine adjustments to the crosshead, protecting your valuable specimen from damage.

BUILT TO LAST

Protecting Your Investment



Instron 2580 Series Load Cells

The 2580 Series load cells are specifically designed for use with 6800 testing systems, offering exceptional performance with the ability to measure forces as low as 1/1000th of the force capacity to an accuracy of $\pm 0.5\%$ of reading. The Instron® designed and manufactured load cells can withstand loads up to 150% of their force capacity without damage and 300% without mechanical failure. Automatic transducer recognition and electrical calibration makes them easy to use.



Collision Mitigation

Reduce damage to equipment and delicate specimens by stopping the crosshead if force is detected upon return or during a jog.



Load Cell Overload Protection

The 6800 series systems automatically stop when the load cell reaches maximum capacity to prevent damage to the load cell, system, and accessories.



Stiff Frames for High-Strength Materials

The 6800 is built for high performance. It features pre-loaded bearings, precision ball screws, an extra thick crosshead and base beam, and low-stretch drive belts to ensure superior performance and longevity.

Precision Guidance for Alignment and Bending

When performing a uniaxial test, accurate stress and strain results can only be achieved with a system that contains robust, precise guidance columns that ensure minimal specimen bending under load.

Larger Motors for Better Reliability

The 6800 load frames use powerful motors with reserve capacity that allow for quicker rates of acceleration. Maintenance-free brushless AC servomotors enable cyclic, creep, and relaxation testing for up to 10 days (up to 1Hz at 25 °C).

Servo-Controlled Drive System

Along with a powerful motor, the 6800 drive system consists of a rugged steel casting with a dual-belt drive system. Unlike systems that use gear-reducers, which create backlash and lower drive system stiffness, the dual-belt system provides synchronous movement of the ball screws, eliminating crosshead tilt and aiding system alignment.

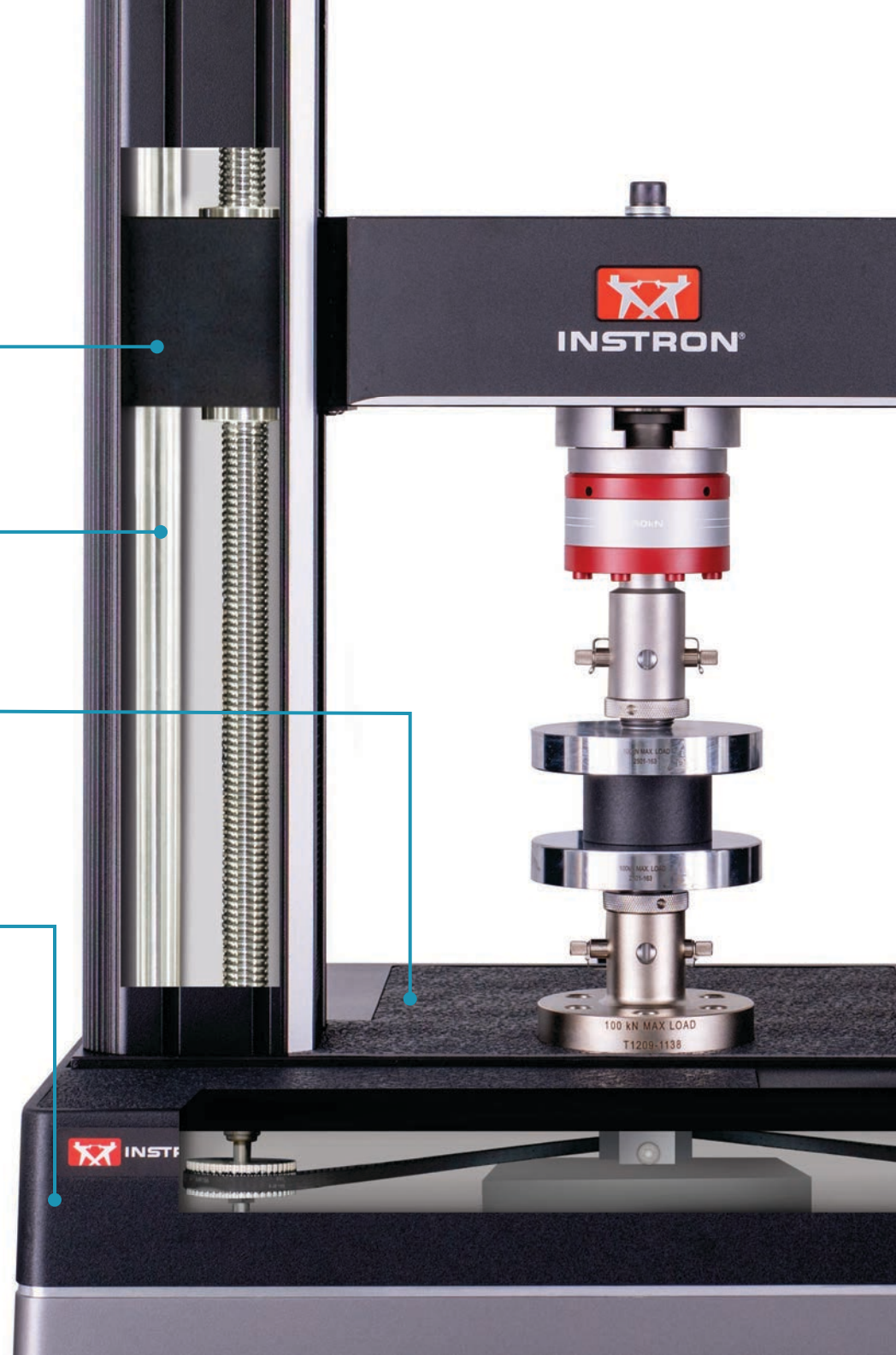

SUPPORT FOR THE LIFE OF YOUR EQUIPMENT

Protecting Your Investment

Instron® is among the largest supplier of materials testing systems in the world. Our reliable testing systems are designed to run critical tests 24 hours a day. However, if something does go wrong, or if you have a question, we offer a variety of resources to ensure you receive the assistance you need as soon as you need it.



Instron Connect

Instron connect allows you to securely share your screen with Instron service professionals and submit service requests directly through your test system. You can also use this portal to easily send test methods and sample data files for review.

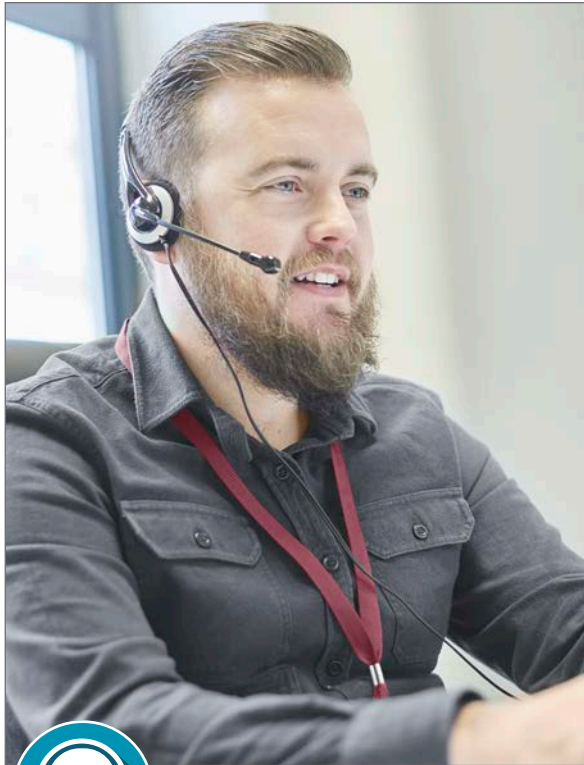

Remote Support

6800 Series testing systems can send errors and diagnostics to our expert technical support teams around the world for troubleshooting.



Training

Training courses are available on-site, regionally, at an Instron factory, or online. Utilize our Applications Engineering Lab or Custom Solutions Group for the latest technological advances in materials testing.

SCAN THE QR CODE
to learn more about how Instron
can help protect your investment.

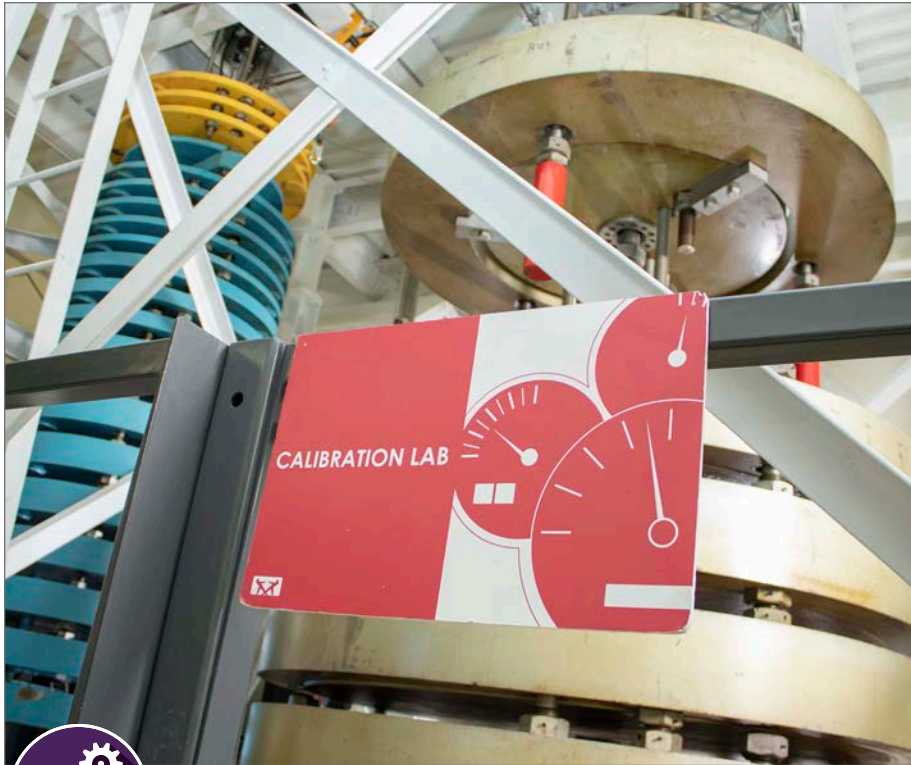

Calibration

Our state-of-the-art Calibration Laboratory offers a comprehensive range of accredited calibration and verification services complying with ASTM, ISO, and Nadcap standards for force, speed, strain (extensometers), displacement, impact, temperature, torque, creep, strain gauge channel, and alignment.



On-Site Services

When on-site assistance is needed, our team of 300+ global service engineers can help get you back up and running. Our factory-trained technicians are located all around the world and speak 40+ languages to help solve problems no matter where they occur.

6800 SERIES SPECIFICATIONS

6800 Single Column Series

		68SC-05	68SC-1	68SC-2	68SC-5
Force Capacity	kN	0.5	1	2	5
	lbf	112	225	450	1125
Crosshead Travel	mm	505	868	868	868 (E1), 1112 (E2)
	in	19.9	34.2	34.2	34.2 (E1), 43.8 (E2)
Vertical Test Space (A)	mm	738	1118	1118	1118 (E1), 1375 (E2)
	in	29.1	44.0	44.0	44.0 (E1), 54.1 (E2)
Horizontal Test Space (B)	mm	100	100	100	100
	in	3.9	3.9	3.9	3.9
Maximum Speed	mm/min	2540	2540	2540	2540
	in/min	100	100	100	100
Minimum Speed	mm/min	0.001	0.001	0.001	0.001
	in/min	0.00004	0.00004	0.00004	0.00004
Maximum Return Speed	mm/min	2540	2540	2540	2540
	in/min	100	100	100	100
Position Control Resolution	nm	9.5	9.5	9.5	9.5
	µin	0.38	0.38	0.38	0.38
Frame Axial Stiffness	kN/mm	8.5	8.5	8.5	8.5
	lb/in	48500	48500	48500	48500
Maximum Force at Full Speed	kN	0.5	1	2	2.5
	lbf	112	225	450	562
Maximum Speed at Full Force	mm/min	2540	2540	2540	1270
	in/min	100	100	100	50
Footprint Dimensions (h × w × d)*	mm	1020 × 460 × 615	1410 × 460 × 615	1410 × 460 × 615	1410 × 460 × 615
	in	40 × 18 × 24	56 × 18 × 24	56 × 18 × 24	56 × 18 × 24
Weight	kg	55	62	62	62 (E1), 67 (E2)
	lb	121	136	136	136 (E1), 148 (E2)
Maximum Power Requirements	VA	700	700	700	700

* The footprint width is for the system only. The Operator Dashboard monitor may add 300 mm (12 in) to the overall width of the frame. The extra height (E2) option for the 68SC-5 adds 27 cm (10 in) to the overall height of the frame.

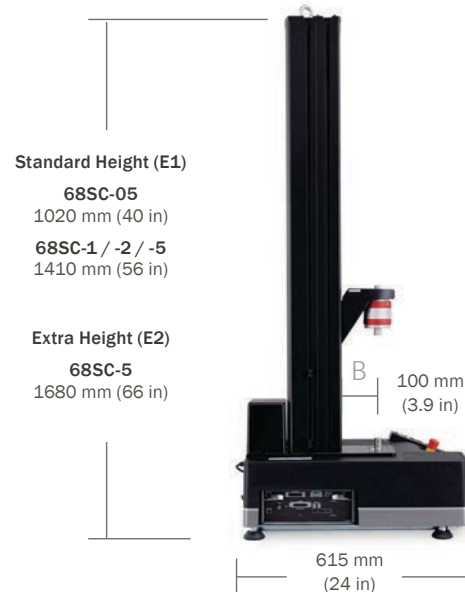

6800 Table Model Series



		68TM-5	68TM-10	68TM-30	68TM-50
Force Capacity	kN	5	10	30	50
	lbf	1125	2250	6750	11250
Crosshead Travel	mm	1163 (E1), 1648 (E2)	1163 (E1), 1648 (E2)	1119 (E1), 1605 (E2)	1119 (E1), 1605 (E2)
	in	45.8 (E1), 64.9 (E2)	45.8 (E1), 64.9 (E2)	44.1 (E1), 63.1 (E2)	44.1 (E1), 63.1 (E2)
Vertical Test Space (A)*	mm	1234 (E1), 1739 (E2)	1234 (E1), 1739 (E2)	1190 (E1), 1695 (E2)	1190 (E1), 1695 (E2)
	in	48.6 (E1), 68.5 (E2)	48.6 (E1), 68.5 (E2)	46.8 (E1), 66.7 (E2)	46.8 (E1), 66.7 (E2)
Horizontal Test Space (B)	mm	420	420	420 (F1), 947 (F2)	420
	in	16.5	16.5	16.5 (F1), 37.2 (F2)	16.5
Maximum Speed	mm/min	3048	2032	1016	762
	in/min	120	80	40	30
Minimum Speed	mm/min	0.001	0.001	0.001	0.001
	in/min	0.00004	0.00004	0.00004	0.00004
Maximum Return Speed	mm/min	3500	2100	1100	800
	in/min	138	83	43	31
Footprint Dimensions (h × w × d)**	mm	1640 × 760 × 715	1640 × 760 × 715	1640 × 756 × 715	1640 × 760 × 715
	in	65 × 30 × 28	65 × 30 × 28	65 × 30 × 28	65 × 30 × 28
Position Control Resolution	nm	9.9	4.9	2.6 (F1), 2.8 (F2)	1.8
	μin	0.39	0.19	0.10 (F1), 0.11 (F2)	0.07
Frame Axial Stiffness	kN/mm	45	50	140 (F1), 88 (F2)	180
	lb/in	256,950	285,500	799,000 (F1), 502,000 (F2)	1,027,000
Maximum Force at Full Speed	kN	2.5	5	15	25
	lbf	563	1125	3372	5620
Maximum Speed at Full Force	mm/min	1524	1016	508	381
	in/min	60	40	20	15
Weight	kg	139 (E1), 154 (E2)	139 (E1), 154 (E2)	196 (E1+F1), 215 (E2+F1) 453 (E1+F2), 471 (E2+F2)	255 (E1), 278 (E2)
	lb	307 (E1), 340 (E2)	307 (E1), 340 (E2)	433 (E1), 473 (E2) 999 (E1+F2), 1038 (E2+F2)	562 (E1), 612 (E2)
Maximum Power Requirements	VA	1400	1400	1400 1500 (F2)	1400

*The F2 option for 68TM-30 reduces test space by 53 mm (2 in).

** The footprint width is for the system only. The Operator Dashboard monitor may add 300 mm (12 in) to the overall width of the frame.
 The extra height (E2) option adds 530 mm (21 in) to the overall height of the frame.

SPECIFICATIONS & REQUIREMENTS

Data Acquisition Rate at the PC:

Up to 5 kHz simultaneous on force, displacement, and strain channels.

Load Measurement Accuracy:

±0.5% of reading down to 1/1000th of load cell capacity. Meets or exceeds ASTM E4, BS 1610, DIN 51221, ISO 7500-1, EN 10002-2, JIS B7721, JIS B7733, and AFNOR A03-501 standards.

Strain Measurement Accuracy:

Meets or exceeds ASTM E83, BS 3846, ISO 9513, and EN 10002-4 standards.

Displacement Measurement Accuracy:

±0.01 mm or 0.05% of displacement (whichever is greater).

Testing Speed Accuracy:

(Zero or constant load) ±0.1% of set speed.

Notes:

These specifications were developed in accordance with Instron's standard procedures and are subject to change without notice. All systems conform to all relevant European standards and carry a CE mark.

Single Phase Voltage:

100, 120, 220, or 240 VAC ±10%, 47 to 63 Hz.

Operating Temperature:

+5 to +40 °C (+41 to +104 °F)

Storage Temperature:

-25 to +55 °C (-13 to +131 °F)

Humidity Range:

+10 to +90%, non-condensing at 20 °C

Ingress Protection (IP) Rating:

IP 2X. Protective measures may be required if excessive dust, corrosive fumes, electromagnetic fields, or hazardous conditions are encountered.





6800 SERIES
the NEXT
GENERATION of
Universal Testing Systems



THE WORLD STANDARD

We stake our reputation on the integrity of data. From the measurement of primary test data to result generation, we design and manufacture the full data integrity chain (e.g. load cells, sensor conditioning, and software). Additionally, we calibrate more than 90,000 of these sensors annually with the lowest accumulated uncertainty.

30,000+

We service and calibrate more than 30,000 Instron systems in active use worldwide every year.

96%

96% of the Fortune 100 list of the world's largest manufacturing companies use Instron test systems.

18,000+

Instron systems have been cited in more than 18,000 patents since 1975.
